



Isaac Newton Institute for Mathematical Sciences

Annual Report 2012–13



UNIVERSITY OF
CAMBRIDGE

Contents

Director's Foreword	1
Institute News	2
Science at the Institute	
Scientific Steering Committee	3
Future Programmes	4
Programme Reports:	
<i>Spectral Theory of Relativistic Operators</i>	5
<i>Topological Dynamics in the Physical and Biological Sciences</i>	6
<i>Multiscale Numerics for the Atmosphere and Ocean</i>	8
<i>Grothendieck–Teichmüller Groups, Deformation and Operads</i>	10
<i>The Mathematics of Liquid Crystals</i>	12
<i>Mathematical Modelling and Analysis of Complex Fluids and Active Media in Evolving Domains</i>	14
Follow-up Meetings	16
Serving the UK Community	
Newton Institute Correspondents	18
Institute Activities	20
Management and Statistical Reports	
Management Committee	22
Programme Participation	23
Finances	26

.....

APPENDICES

The following statistics are available from www.newton.ac.uk/reports/1213/appendices

- 1 Invited Participants
- 2 Junior Members of the Newton Institute
- 3 Nationality and Country of Residence of Participants
- 4 Preprints and Papers Produced by Participants
- 5 Seminars and Lectures
- 6 Seminars Given Outside the Institute

Director's Foreword



The Isaac Newton Institute (INI) is a national facility and a research centre of the first rank internationally. With about 2,000 visitors a year it supports individual researchers and collaborators in pursuit of excellence, with a mandate to cover the entire range of mathematical sciences and their applications. In the USA eight centres are funded by the National Science Foundation to cover ground that is covered by INI. In addition to its research programmes and workshops, INI now runs:

- *Satellite Meetings* which are held in UK venues outside Cambridge to bring the benefit of INI's extensive range of visitors to the wider community;
- *Scoping Meetings* which bring together researchers from several disciplines to examine possibilities of exploiting mathematical developments in their areas. A scoping meeting is especially relevant when a shared language needs to be developed, for example when there is no history of such interdisciplinary work. The goal is to decide whether there is scope for a proposal to INI for a full cross-disciplinary programme;
- *Follow-up Meetings* are events held to examine the impact of INI programmes on research or applications several years on, especially to see if further action is needed to sustain or redirect efforts;
- *Open for Business* meetings are short lecture series in which academic and non-academic researchers explain their achievements to one another with the hope of stimulating research collaborations;
- *Turing Gateway to Mathematics*, an initiative to recognise and reduce the time lag between fundamental research and its application, and to ensure that mathematical challenges from other

disciplines are brought to the attention of mathematicians. A recent report by Deloitte¹ showed the huge contribution made by mathematical sciences research to the UK economy and the *Turing Gateway to Mathematics* is directed towards increasing this impact. With support from the University, INI has appointed a Knowledge Transfer Facilitator to help develop the project. An account of this activity accompanies this report.

All INI lectures (with permission from the speaker) are streamed live and available in perpetuity on the web. Every programme has a web based Discussion Forum so that all participants can remain involved with the research, even if they are unavoidably absent for part of a programme. In this way INI delivers its impact outside Cambridge and beyond the immediate time frame of its programmes.

Recently INI has secured core funding from five research councils for the next four years. While this is very welcome recognition of its cross disciplinary approach and reflects the increasingly prominent role of the mathematical sciences in the strategic planning across the research councils, the ambition to take INI activities to a new levels will be realised only with significant support from other donors whose generosity make a huge difference to what is possible. Thus there is a pressing need to increase INI's endowment funds, so that it can build on its leading position and have the capacity to innovate and act independently in pursuit of research excellence wherever it is found.

INI is involved with the scientific life of the country in other ways: for example, in December the Council of EPSRC held its winter meeting here and INI hosted the UK launch event for the worldwide programme *Mathematics of Planet Earth 2013* (see page 2). In March it organised an invited lecture during the *Cambridge Science Festival* and in April it hosted the UK's *Women in Mathematics Day*.

Sir John Ball is now retiring after two terms in the chair of the Scientific Steering Committee (SSC) and a term as an ordinary member. It is the SSC that ensures INI scientific programmes are of the highest quality by international standards and John's commitment and leadership have been exceptional. We are greatly in his debt. Finally, I am pleased to report that Professor Peter Landshoff has been made an Honorary Fellow, in recognition of outstanding contributions to INI from its very earliest days.

¹ <http://www.epsrc.ac.uk/SiteCollectionDocuments/Publications/reports/DeloitteMeasuringTheEconomicsBenefitsOfMathematicalScienceResearchUKNov2012.pdf>

Institute News

Mathematics of Planet Earth

On 10 December 2012 the Isaac Newton Institute hosted the UK launch of *Mathematics of Planet Earth 2013* (MPE2013) which is a worldwide initiative endorsed by UNESCO. The goals of MPE2013 are: to formulate the most urgent planetary problems that mathematics can address; to bring together world-class researchers to find solutions to these problems; and to engage the public in a dialogue about the significance of these problems.

The launch at the Institute, *The Mathematics of Extreme Climatic Events*, included an afternoon of talks by leading mathematicians, scientists and policy makers. They discussed how mathematical models and statistical analysis help us to predict, manage impact, exploit and communicate about nature's climatic extremes, and how these help Government to anticipate health-related consequences of natural catastrophic events and insurance companies to assess the financial risk of such occurrences.

All of the talks and the panel discussion session can be viewed or downloaded from the web at www.newton.ac.uk/programmes/INI/iniw92p.html



David Spiegelhalter

Funding update

In September 2012, the Institute made an agreed proposal to the research councils collectively for funding for 4 years from 2014. The proposal was collectively scored 35/36 by six referees and an announcement that it will be fully funded was made at the end of March 2013.

INI is extremely grateful for the generous support of organisations and individuals throughout the year (see pages 27–28). Donations provide a valuable source of income to support the world class research undertaken by those who visit the INI annually. If you would like to contribute to the success of the Institute in this way, details can be found at www.newton.ac.uk/support.

Interview with Jerry Ericksen

In a vivid illustration of the impact of new technologies on activities at the Institute, *Mathematics of Liquid Crystals* programme organiser Sir John Ball held a videoconferencing interview with Professor Jerry Ericksen, who is based in Oregon. Professor Ericksen (below left) is one of the founding fathers of the theory, and gave a gripping account of how his ideas developed. See the interview at www.newton.ac.uk/programmes/MLC/seminars/2013053011001.html.



TGM Turing Gateway to Mathematics

This year saw the launch of the *Turing Gateway to Mathematics*, an initiative with a national remit that aspires to facilitate the flow of knowledge and ideas from the mathematical sciences to potential users – in short, acting as a gateway! With activities ranging from specific projects to more extensive training and research programmes, the Gateway can help bridge the gap between academic mathematicians, business, government, and other disciplines. As well as focusing on widening access to mathematics generally, the TGM can also help shorten pathways to impacts and strengthen education and training in areas where maths skills are needed.

Further details on Gateway activities are available at www.turing-gateway.cam.ac.uk.

Science at the Institute



John Ball
Chair of the Scientific
Steering Committee

The depth and diversity of the programmes has once again been extraordinary including:

- *Spectral Theory of Relativistic Operators;*
- *Topological Dynamics in the Physical and Biological Sciences;*
- *Multiscale Numerics for the Atmosphere and Oceans;*
- *Grothendieck–Teichmüller Groups, Deformation and Operads;*

- *Mathematics of Liquid Crystals;*
- *Mathematical Modelling and Analysis of Complex Fluids and Active Media in Evolving Domains.*

This year I had the opportunity to experience first-hand as a co-organiser of the *Mathematics of Liquid Crystals* programme the outstanding research environment that the Isaac Newton Institute provides.

As the intrinsic mathematical nature of many problems in science and society is increasingly being recognised, so the huge diversity of the mathematics covered in the Institute’s programmes is growing. This places a significant burden on the Scientific Steering Committee, which it manages very well. I am indebted to them for their support. I wish to thank in particular Reidun Twarock and Trevor Wooley who, like myself, are retiring from the Committee this year. It has been a pleasure to work with the INI staff and three Directors, and I wish them continuing success for the future.

Scientific Steering Committee

Membership of the Scientific Steering Committee at 31 July 2013 was as follows:

Name	Institution	End of Service
Sir John Ball FRS FRSE (Chair)	University of Oxford	31 Dec 2013
Professor Muffy Calder FRSE	University of Glasgow	31 Dec 2014
Professor Steve Cowley	Atomic Energy Authority	31 Dec 2016
Professor Michael Harris	Institut de Mathématiques de Jussieu	31 Dec 2016
Professor Wilfred Kendall	University of Warwick	31 Dec 2014
Professor John Lygeros	ETH Zürich	31 Dec 2015
Professor Sylvia Richardson	University of Cambridge	31 Dec 2015
Dr Emily Shuckburgh	British Antarctic Survey	31 Dec 2016
Professor Endre Süli	University of Oxford	31 Dec 2014
Professor Richard Thomas	Imperial College, London	31 Dec 2015
Professor John Toland FRS FRSE (Secretary)	Director, Newton Institute	30 Sep 2016
Professor Reidun Twarock	University of York	31 Dec 2013
Professor Cédric Villani	Institut Henri Poincaré	31 Dec 2014
Professor Trevor Wooley FRS	University of Bristol	31 Dec 2013
Professor Keith Ball (<i>ex-officio</i>)	ICMS	–

The Scientific Steering Committee (SSC) meets twice each year to consider proposals for programmes (of 4-week, 4-month or 6-month duration) to run two or three years later. Successful proposals are usually developed in a discussion between the proposers and the SSC conducted through the Director, and may well be considered at more than one SSC meeting before selection is recommended. Proposers may wish to submit a shorter ‘preliminary’ proposal in the first instance with a view to obtaining feedback from the SSC prior to the submission of a ‘full’ proposal. Complete details of the Institute’s regular call for proposals, including guidelines for submission, can be found on the Institute’s website at www.newton.ac.uk/callprop.html.

Future Programmes

The schematic below shows recent and forthcoming programmes selected by the Scientific Steering Committee. Long-stay participation in a programme is at the invitation of the programme organisers; anyone interested should contact them directly. One- or two-week workshops are advertised, and applications invited with specific deadlines. Visits of one or two days are always welcome; we ask only that reception@newton.ac.uk is emailed in advance to assist us with planning; see page 20 for more details.

Further details of each of these programmes, including the names and contact details of the organisers, can be found on the Newton Institute website at www.newton.ac.uk/programmes/. Further information on how to participate in programmes can also be found on the website at www.newton.ac.uk/participation.html.

	JAN	JUL	SEP	DEC
2012	<i>Mathematics and Applications of Branes in String and M-Theory</i>		<i>Topological Dynamics in the Physical and Biological Sciences</i>	
	<i>Semantics and Syntax: A Legacy of Alan Turing</i>	<i>Spectral Theory of Relativistic Operators</i>	<i>Multiscale Numerics for the Atmosphere and Ocean</i>	
2013	<i>The Mathematics of Liquid Crystals</i>		<i>Polynomial Optimisation</i>	<i>Mathematical Challenges in Quantum Information</i>
	<i>Grothendieck–Teichmüller Groups, Deformation and Operads</i>	<i>Mathematical Modelling and Analysis of Complex Fluids and Active Media in Evolving Domains</i>	<i>Infectious Disease Dynamics</i>	<i>The Holographic Principle</i>
				<i>Mathematics for the Fluid Earth</i>
2014	<i>Free Boundary Problems and Related Topics</i>		<i>Theory of Water Waves</i>	<i>Understanding Microbial Communities: Function, Structure and Dynamics</i>
	<i>Inference for Change-Point and Related Processes</i>	<i>Mathematical, Statistical and Computational Aspects of the New Science of Metagenomics</i>	<i>Advanced Monte Carlo Methods for Complex Inference problems</i>	<i>Interactions between Dynamics of Group Actions and Number Theory</i>
		<i>Quantum Control Engineering</i>	<i>Systemic Risk: Mathematical Modelling and Interdisciplinary Approaches</i>	
2015	<i>Periodic and Ergodic Spectral Problems</i>		<i>Metric and Analytic Aspects of Moduli Spaces</i>	<i>Mathematical, Foundational and Computational Aspects of the Higher Infinite</i>
	<i>Random Geometry</i>		<i>Coupling Geometric PDEs with Physics for Cell Morphology, Motility and Pattern Formation</i>	

Key: nominal programme duration 6 months 4 months 2 months 1 month

Spectral Theory of Relativistic Operators

23 July to 17 August 2012

www.newton.ac.uk/programmes/SRO/

Report from the Organisers:

Malcolm Brown (Cardiff), Maria J Esteban (Paris), Karl Schmidt (Cardiff) and Heinz Siedentop (München).



Maria Esteban

This one-month programme focused on the relativistic quantum theory of graphene, a one-layer honeycomb lattice of carbon atoms with significant potential for innovative industrial applications. The challenge, to understand the electromagnetic properties of this intriguing material from a mathematical perspective, led experts in relativistic quantum mechanics and in the analysis of Dirac operators into areas which had previously been only of fringe interest to both communities. From the mathematical perspective the question was how to locate

eigenvalues of the Dirac operators, how to compute them, and how to get a priori or a posteriori errors for such computations. However the programme was entirely interdisciplinary, crossing the boundary between physics and mathematics, and wandering into areas of quantum chemistry.

It began with *A Gentle Introduction to the Physics of Graphene*, which was in fact an intensive mini-course designed by Marquardt to familiarise participants with the physical and mathematical modelling of graphene.

In *Ground State Properties of Graphene in Hartree–Fock Theory* Lewin presented joint work with Hainzl and Sparber on relativistic multi-particle systems. Such problems pose fundamental mathematical challenges because the Dirac equation lacks lower semi-boundedness and physical intuition seems ineffective. Lewin showed how translation-invariant ground states for a mean-field model of graphene can be constructed and how, due to the exchange term, the resulting effective Fermi velocity is logarithmically divergent at zero momentum. He then established the existence of ground states in the presence of local defects and discussed properties of the associated nonlinear responses. This is important because relativistic multi-particle problems occur naturally and have practical relevance in quantum chemistry.

Solovej presented his breakthrough proof with Lieb of a 1978 conjecture about the classical entropy of quantum states. A further highlight was the seminar by Lieb on inequalities for quantum entropy which are relevant for quantum information and have potential applications in quantum computing.

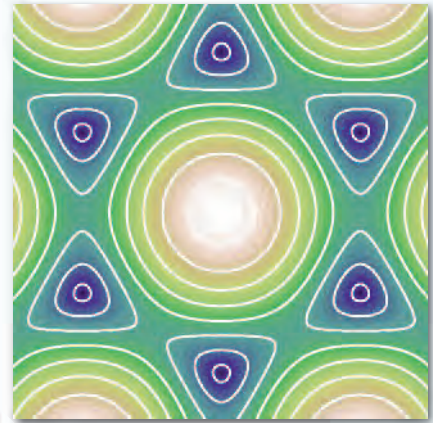

This image shows the energy band structure of graphene, with its characteristic hexagonal structure and with the Dirac points (small circles). The white lines indicate paths of constant energy in this momentum space plot. (Image courtesy of Florian Marquardt)

An important objective of the programme was to break down barriers between areas and initiate new interactions and research collaborations, and that was achieved. Indeed several participants announced specific results discovered collaboratively during the programme. A notable example was research on the N -representability of two-particle density by Bach, Knörr, Menge and Siedentop, which will have impact on both relativistic and non-relativistic multi-particle theory.

The length of the programme, one month, was appropriate for this focussed event with a very high level of engaged participation, staking out the boundaries of an exciting, lively and rapidly evolving area of research which has interfaces with a great many established fields. It attracted regular day visitors from institutions outside Cambridge, notably the London colleges, because it dealt with issues of great practical importance in the natural sciences and their technical applications.

FACT FILE

No. of participants: 70

Gender Balance:
Male: 61 Female: 9

No. of preprints and papers produced: 8

Topological Dynamics in the Physical and Biological Sciences

16 July to 21 December 2012

www.newton.ac.uk/programmes/TOD/

Report from the Organisers:

Konrad Bajer (Warsaw), Tom Kephart (Vanderbilt), Yoshi Kimura (Nagoya), Keith Moffatt (Cambridge) and Andrzej Stasiak (Lausanne).

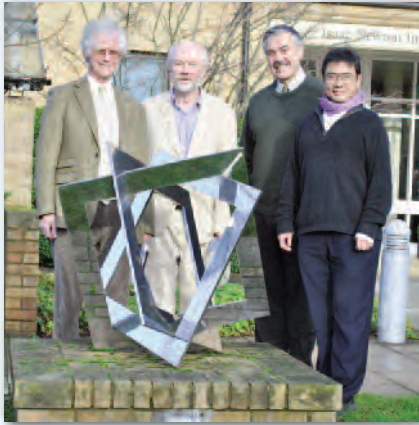

Introduction

This programme was designed to stimulate interactions between applied mathematicians, biologists and physicists who encounter dynamical problems in which structures, such as knots or links, that remain invariant under continuous deformations play a significant role. The evolution of such systems must reflect the integrity of these persistent structures (called

topological invariants) and basic problems, common to them all are: to determine states of minimum energy that are consistent with these constraints; to find routes towards these minimum energy states; to understand mechanisms, such as diffusion, by which such constraints may be broken.

The programme was planned around four themes (outlined below) and significant numbers participated for four months or more, thereby linking the themes and giving the programme strong coherence and continuity. There were two seminars each week, and many mini-lectures and discussions proposed by individual participants with ample time for reflection and for new ideas to be developed through informal discussion.

Theme 1: Vortex Dynamics

The first event provoked discussions that were a source of stimulation for the remainder of the programme. This was a symposium, sponsored by the International Union of Theoretical and Applied Mechanics (IUTAM) with Proceedings *IUTAM Symposium on Topological Fluid Dynamics: Theory and Applications*, published in hard copy and online (open access) by Elsevier www.sciencedirect.com/science/journal/22109838/7

A lecture by M Brøns, in tribute to Hassan Aref (Virginia Tech) who had served on the Symposium Committee until his unexpected death in September 2011, concerned recent advances on classical problems of equilibrium (rotating) configurations of point vortices. Further highlights were lectures by A Enciso and D Peralta-Salas on their remarkable discovery that for an arbitrary knot there exists an analytic Beltrami flow



Material line pattern for a three-braid 'pseudo-Anosov' mixer after three periods (courtesy SE Tumas and J-L Thiffeault)

(the vorticity is everywhere parallel to the velocity) for which the knot is a vortex line; lectures by P Boyland, M Stremler, and J-L Thiffeault, on pioneering work (partly

in collaboration with Aref) on the application of Thurston–Nielsen theory to the stirring of a fluid by the periodic movement of three or more rods.

Theme 2: DNA Function and Protein Folding

This theme focused on the modelling of DNA molecules subject to topological constraints, the action of DNA topoisomerases, DNA recombination and its mechanisms, chromosomal architecture, folding mechanisms of knotted proteins, and the function of knots in proteins. D Buck and DW Sumners opened this event with powerful presentations on the importance of topological concepts in understanding sub-cellular biological processes.

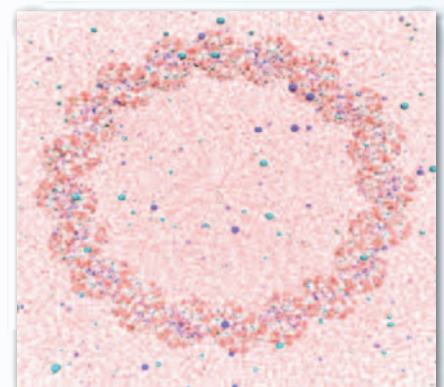

An explicitly solvated starting structure (110 bp, 0.1 mol NaCl) showing DNA and counter ions in a space-filling representation (courtesy JS Mitchell, CA Laughton and SA Harris, *Nucl. Acids Res.* 2011)

FACT FILE

No. of participants: 273

Gender Balance:

Male: 231 Female: 42

No. of preprints and papers produced: 51

Rothschild Distinguished Visiting Fellow:

Sir Michael Berry

Microsoft Visiting Fellow:

De Witt L Sumners

At an *Open for Business* event, *Maths meets Molecular Biology at the Newton Institute*, CM Dobson FRS, Master of St John's College, lectured on the understanding and treatment of neurodegenerative diseases, and Sir Gregory Winter FRS, Master of Trinity College, spoke about the building of therapeutic drugs based

“the programme succeeded in promoting collaborations between mathematicians and physical and biological scientists, and identified problems that will be challenging for years to come”

on proteins. Another noteworthy was the lecture of L Zechiedrich (Baylor College of Medicine, Houston, Texas) on how basic DNA topology research has opened doors for gene therapy.

The journal *Nucleic Acids Research* sponsored two prizes for student posters with winners T Sutthibutpong (Leeds) and K Valencia (Imperial

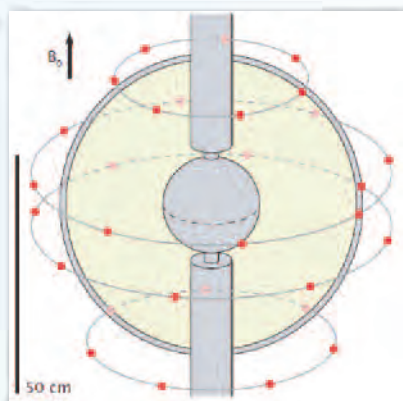

Spherical annulus ‘Taylor–Couette’ experiment; liquid sodium fills the spherical annulus, an axial magnetic field is applied, and the boundary spheres may be independently rotated. Hall probes are placed at 30 points as indicated (courtesy DA Lathrop, Phys. Rev. E 2010)

College London) and topical mini-reviews from the workshop featured in the April 2013 issue of *Biochemical Society Transactions*.

Theme 3: MHD in Astro- and Plasma Physics

This theme involved sustained interactions between C Parnell, K Bajer, Y Kimura, K Moffatt and G Hornig, with particular focus on braiding of magnetic fields and formation of current sheet discontinuities. A *Satellite Meeting* was held at ICMS, Edinburgh, at which lectures by A Title (Lockheed) showing maps of solar magnetic field topology and evolution, and by DA Lathrop (Maryland) on his experiments in metallic sodium and liquid helium, were particularly notable.

Theme 4: Quantized-Flux Systems

The recurrent theme of knotted and linked quantized flux culminated in December with a workshop organised by N Berloff, J Cantarella, A-C Davis, T Kephart, P Sutcliffe and T Vachaspati. During the workshop Sir Michael Berry (Bristol) gave the Rothschild Seminar *Superoscillations and Weak Measurement*.

Throughout the programme, K Millett, J Cantarella, C Shonkwiler, R Kusner, and others were heavily involved with fundamental issues of the energy spectrum of knots and links, of tightening, of relaxation to local and global minima, and of topological aspects of stability related to helicity. A final workshop turned to quantized helicity and its generalizations, curvature, distortion and other physical corrections, with application to quantum reconnection and tunneling, monopole-anti-monopole pair production, and universality aspects of tightly knotted systems of quantized flux, from super-conductors to glueballs in QCD.

Proceedings of the 3rd and 4th workshops are being published with online open access by the Institute of Physics.



A tight knot (7_2) in the geometrical configuration that minimizes the ratio of ropelength to diameter (courtesy J Cantarella)

The Seminar Programme

The seminar programme started with P Boyland's *Some topological tools in two-dimensional dynamics* and ended with S Nazarenko's *Quadratic invariants for clusters of resonant wave triads*. To illustrate the wide scope in between: A Herczynski spoke on painting with viscous jets, a retrospective analysis of the painting technique of Jackson Pollock, inspired by sinusoidal tracks evident on his canvases; W Irvine discussed his experimental creation of a knotted vortex and the manner in which it reconnects to form two unlinked vortex rings; C Parnell gave a beautiful presentation of the topology of complex magnetic fields of the Sun and the magnetosphere; and T Kephart reported on his updated theory (with R Buny) on the tight knot spectrum of glueballs in quantum chromodynamics.

In conclusion the INI was a perfect setting for this ambitious and wide-ranging programme which succeeded in promoting collaborations between mathematicians and physical and biological scientists, and identified problems that will be challenging for years to come.

Multiscale Numerics for the Atmosphere and Ocean

22 August to 21 December 2012

www.newton.ac.uk/programmes/AMM/

Report from the Organisers:

David Ham (Imperial), Todd Ringler (Los Alamos), Hilary Weller (Reading) and Nigel Wood (Met Office).



Background

The over-arching aim of this programme was to discover new mathematical techniques that would lead to more accurate and efficient simulations of the earth's atmosphere and oceans in order to improve the accuracy of weather forecasting and climate prediction. Pressure for improved methods was coming from operational centres which were understandably making increasing demands on the reliability of models and the scientific quality of outputs.

It had long been hoped that adaptive meshing (see Fig. 2) would address these issues. However that promise has not been realised and recent changes in computer architecture have led to an urgently need for new

algorithm for static meshes that would work efficiently on massively parallel computers with low memory bandwidth. Moreover the ever increasing complexity of models that are needed to answer extremely complicated and subtle scientific questions require higher resolution and wider process coverage than ever before.

This almost insatiable demand for computational resources from weather forecasters and climate modellers can be met by the next generation of supercomputers with their overwhelming increase in core counts and use of accelerators. But the efficiency of these new machines demands reduced memory access, improved parallel scalability of the code and in some cases major rewrites of existing code and formulations.

The programme aimed to develop new mathematics to handle these developments and research themes investigated included: the detailed numerical analysis of discretisation methods; implicit solution techniques and sparse matrix solvers; design of the next generation Met Office weather and climate forecasting models; mesh adaptivity; speculative new time-stepping methods, and much more. Some of the outcomes are now being adopted by meteorological forecasting centres.

Outcomes and Achievements

Gung Ho is a UK-based project to design numerical methods for efficient and accurate weather and climate prediction on the anticipated architectures of exascale super-computers; it will be at the core of the next Met Office model. During the programme, decisions were taken about the mathematical

methods to be used in that model and an entirely new software framework began to take shape to deliver the full benefits of these scientific developments to the general public.

A recurring theme was the need to distinguish between real wave propagation in a climate or weather system and spurious wave propagation that is merely a feature of numerical modelling and does not represent reality. New analysis of continuous and discontinuous finite elements, mixed finite elements and finite volumes, revealed that all discretisations of the equations of motion admitted spurious computational modes (usually arising as spurious, stationary grid-scale oscillations) which can be controlled by upwinding or filtering. So called discontinuous Galerkin methods suffer least from spurious artefacts and progress was made in creating implicit solution techniques in that context.

Advances were made with local time-stepping that will be used by a number of modelling centres and innovative new time-stepping approaches for massively parallel architectures and GPUs were developed (see Fig. 1).

The programme offered a much needed opportunity to compare numerical methods, by creating new test cases and revisiting old ones. For example:

- shallow water test cases were undertaken by independent groups to compare local mesh refinement strategies;
- improved numerical methods now allow multiscale simulations of the global ocean, with the capacity to resolve the locally mesoscale eddies which

FACT FILE

No. of participants: 205

Gender Balance:
Male: 179 Female: 26

No. of preprints and papers produced: 19

Rothschild Distinguished Visiting Fellow:
Max Gunzburger

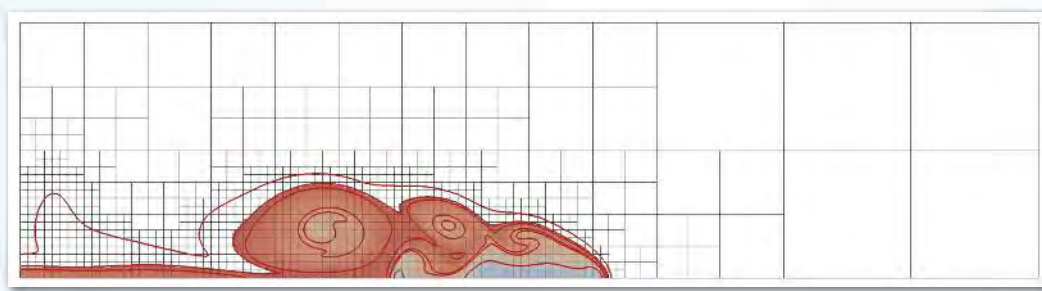

Fig. 1: Discontinuous Galerkin results (from Kopera and Giraldo) dynamically adapting to a buoyancy current

are important because they produce the majority of poleward ocean heat transport and the nonlinear interactions between ocean and atmosphere. New test cases were developed to test a model's ability to simulate such mesoscale ocean activity.

Dynamic Adaptivity

Non-conforming Adaptive Mesh Refinement (AMR), r -adaptivity for unstructured meshes on the sphere, and variable resolution for spectral models were improved. For example, Kopera and Giraldo worked on a unified AMR strategy for a discretisation of the shallow-water equations and Euler equations. Their work showed very good accuracy when the mesh is non-conforming and may soon be used for US Navy weather forecasts.

Representation of sub-grid-scale processes

The use of variational multiscale methods to represent the effects of sub-grid scale processes and filter high frequency variability were developed and will be

implemented in the Community Earth System Model (CESM). New derivations of ocean parameterisations that were shown to work well across a large range of spatial scales will be implemented in the MPAS ocean code <http://mpas-dev.github.io/ocean/ocean.html> which will form part of the Community Earth System Model.

Workshops

Adaptive Multiscale Methods for the Atmosphere and Ocean. Dynamically adaptive simulation techniques based on mesh refinement, mesh movement and polynomial order increase, were presented for ocean and atmosphere applications, as were recent developments in numerics suitable for unstructured and adaptive meshes. Some presentations demonstrated the performance and/or qualitative advantages of using adaptive techniques. However, whether adaptive techniques provide an advantage in more general classes of ocean and atmosphere simulation remains open. The workshop

included presentations from Continental Europe, North America and Asia.

The workshop series *Solution of Partial Differential Equations on the Sphere* has for 20 years served as a beacon of progress in the numerical modelling of global atmosphere and oceans. Its meeting at the Institute saw notable improvements in finite-volume collocated methods, discontinuous Galerkin methods, unstructured finite-volume methods and high-order transport schemes.

Weather and Climate Prediction on Next Generation Supercomputers: Numerical and Computational Aspects was a *Satellite Meeting* held at the UK Met Office in Exeter. The main topics covered were: the state of the art of weather and climate modelling; the outlook in a historic context; discretisations, equation-sets, grids and solvers for the resulting systems; operational aspects of weather and climate modelling; computational trends, limiters and opportunities.

Lectures were delivered by representatives from the leading national weather prediction and climate forecasting centres: DWD (Germany); NCAR (USA); ECMWF (Europe); Met Office (UK) and the US Navy; and there was significant representation from the high performance computer industry, CRAY and IBM, and several academic institutions. There were delegates from Australia, Brazil, Canada, China, France, Italy, New Zealand and Russia.

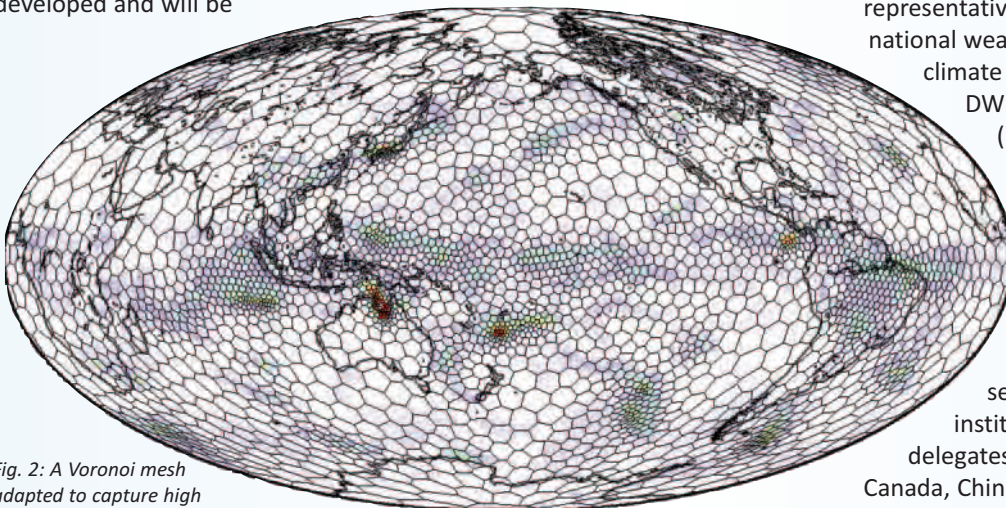

Fig. 2: A Voronoi mesh adapted to capture high observed precipitation (Hilary Weller)

Grothendieck–Teichmüller Groups, Deformation and Operads

3 January to 26 April 2013

www.newton.ac.uk/programmes/GDO/

Report from the Organisers:

Herbert Gangl (Durham), John Jones (Warwick), Pierre Lochak (Paris VI), Bruno Vallette (Nice) and Nick Woodhouse (CMI).

Programme Partner:

Clay Mathematics Institute.

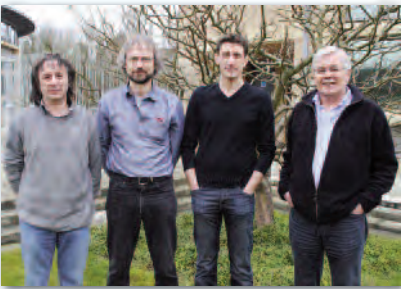

State of the art

This programme is at the crossroad of current research in algebra, geometry, topology and mathematical physics. Grothendieck–Teichmüller theory goes back to the 1980s with Grothendieck’s celebrated *Esquisse d’un programme* (sketch of a programme), whose purpose was to go beyond Galois theory using the geometry of surfaces. In 1991, Drinfeld related it to number theory

and to deformation theory. On the other hand, the notion of an operad, which was introduced in Algebraic Topology over half a century ago, has enjoyed a renaissance in the 90’s notably in the works of Kontsevich in deformation theory. Two proofs of the deformation quantization of Poisson manifolds, one by himself and one by Tamarkin, led Kontsevich to conjecture an action of a Grothendieck–Teichmüller group on such deformation quantizations, thereby indicating a precise relationship between these two topics which lay at the heart of this programme.

Goals and topics

In the past few years, seminal results have been proved at the intersection of Grothendieck–Teichmüller theory, homotopical deformation theory, operads and multiple zeta values. These fields are now entangled and the goal of this programme was to explore and exploit their synergy and to open new avenues of research.

The main programme topics were:

- Operads (Koszul duality theory, homotopy algebras, moduli space of curves, Deligne conjecture);
- Deformation quantization (Lie bialgebras, Hopf algebras, Poisson manifolds, Kashiwara–Vergne conjecture, Duflo isomorphism);
- Grothendieck–Teichmüller theory (absolute Galois group, GT groups and GT Lie algebras, Drinfeld associators);
- Multiple zeta values (mixed Tate motives, polylogarithms, shuffle algebra, Deligne–Ihara algebra).

Programme structure

Because of its multi-faceted nature, the programme opened with an introductory workshop (8–10 January 2013) in which the speakers presented a wide range of topics and participants coming from different fields began to interact.

The backbone of the programme was made up of four short courses (January to March 2013), each spaced throughout the month and covering one of the aforementioned topics. Because the intent was pedagogical, these courses, which included exercise sessions mainly intended for students and non-experts, played an important if not decisive role in ‘putting the pieces together’, both from a scientific and social viewpoint. They were organised in such a way as to make them logistically accessible to the students in nearby Universities and were made available online after a few days.

...the speakers presented a wide range of topics and participants coming from different fields began to interact.

In addition advanced mini-courses were organised to take advantage of the presence of experts participants, thus enabling international leaders to present recent results and theories in great detail.

Finally, a weekly seminar series made it possible for a sizable number of participants to present their own work.

FACT FILE

No. of participants: **183**

Gender Balance:

Male: **154** Female: **29**

No. of preprints and papers produced: **18**

Rothschild Distinguished Visiting Fellow:

Don Zagier

Microsoft Visiting Fellow:

Ezra Getzler

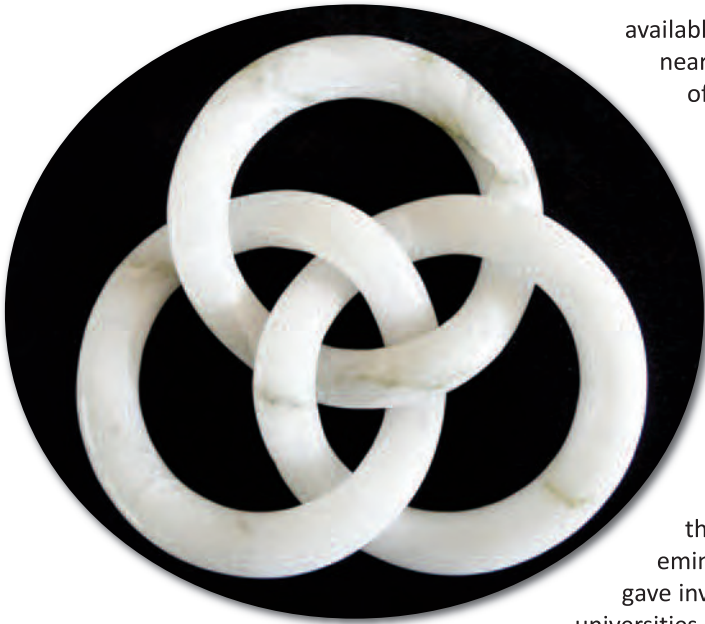

These events often lasted an entire afternoon, recalling definitions and background and going into the details of the proofs.

At the end of March 2013, the many long-term participants took part in two international workshops: *Higher Structure 2013: Operad and Deformation Theory* (2–5 April 2013) and *Grothendieck–Teichmüller Theory and Multiple Zeta Values* (8–12 April 2013) during which experts presented recent advances in the field.

Finally, a *Satellite Meeting* (15–16 April 2013) was organised with the Clay Mathematics Institute at the University of Oxford on the broader topic of *Higher Structures in Topology and Number Theory*. Two of the keynote speakers were Rothschild Distinguished Visiting Fellow Don Zagier, and Microsoft Visiting Fellow Ezra Getzler.

Outcomes and achievements

The programme had 90 participants from all over the world and the various workshops were attended by over 200 people. All the talks, including the lecture series, were recorded, which now provides the mathematical community with an extremely useful database on the subject. A total of 108 talks are

available, representing nearly one terabit of data. By July 2013, there had been 30,000 views had been counted.

Although these fields of research have been somewhat under-represented in the UK, many eminent participants gave invited talks in UK universities and this

programme helped spread these new ideas across the country. Moreover a number of students were able to attend the activities of the programme, notably thanks to the financial support of the Clay Mathematical Institute.

The most obvious scientific outcome of the programme is the creation of a new community of researchers straddling the boundaries of algebra, geometry, topology and mathematical physics.

Thanks to the programme and the interaction of experts coming from these various fields, the following essential results have been demonstrated:

- The notion of an operad was proved to organise various algebraic structures emerging from Multiple Zetas Values (e.g. shuffle and stuffle products), Grothendieck–Teichmüller theory, and modern homotopy theory; Conversely specific number-theory oriented fields like Grothendieck–Teichmüller theory do provide researchers in operad theory with new seminal applications (interpretation of Drinfeld’s associators as morphisms of operads);
- The deformation theory of morphisms of operads

introduced a new and crucial way of describing the Grothendieck–Teichmüller Lie algebra;

- Last but not least, the deformation quantization of Poisson manifolds has been shown to admit a natural faithful action of the prounipotent Grothendieck–Teichmüller group.

The most obvious scientific outcome is the creation of a new community of researchers straddling the boundaries of algebra, geometry, topology and mathematical physics.

Multimedia Activity

One should take special note the crucial role played by the recorded lectures. Participants arriving after the programme had begun, as well as those who had left, benefitted from continuing involvement with the entire programme online. Moreover students from outside the Cambridge and London area could attend the weekly courses in full.

Publications

At least one book covering the entire activity of the programme is in preparation. It should provide a fairly complete and accessible view of the new research field of mathematics consisting of the four topics covered in the programme. Research by the participants will be published in high quality journals and since some of them feature breakthroughs in their respective fields they are likely to appear in the highest quality journals in the world.

The Mathematics of Liquid Crystals

7 January to 5 July 2013

www.newton.ac.uk/programmes/MLC/

Report from the Organisers:

John Ball (Oxford),
David Chillingworth (Southampton),
Mikhail Osipov (Strathclyde),
Peter Palffy-Muhoray (Kent State),
Mark Warner (Cambridge).



Liquid crystals are materials that flow like liquids but retain orientational and in some cases positional order due to the arrangement of their constituent molecules. They were discovered in the late 19th century, but it was only in the 1960s that their immense technological potential for electronic displays began to be realized, leading to their present widespread use in computers, televisions, watches and other applications. At about the same time mathematicians became interested in theoretical models for liquid crystals that had been developed by Oseen, Frank and others, and a fertile period ensued in which the models were refined and attacked using powerful tools of nonlinear analysis.

This programme aimed to take advantage of a second wave of interest by mathematicians in the area, stimulated in part by the newer tensor order-parameter theory of de Gennes, in part by recently discovered liquid crystalline materials such as liquid crystal elastomers and active nematics, and in part by the developing potential of nonlinear and topological analysis to address the challenges of describing liquid crystal defects and other phenomena. At the same time many of the mathematical issues arising in the study of liquid crystals, such as the rigorous passage from atomic and molecular to continuum models and the mathematical description of defects, are of core interest in the description of solids, fluids and other types of soft matter, with a clear potential for cross-fertilization. The proposal for this programme was prepared with the help of a large number of world experts in different aspects of the subject (chemistry, physics, simulation, nonlinear analysis), most of whom spent extended periods at the Institute.

The many topics addressed in the workshops, seminars, informal lecture courses, discussion groups and individual interactions included the following:

- Density functional theory for single and multi-component liquid crystal systems, its use to predict quantities such as elastic constants and surface behaviour, and its relation to continuum theories;
- Generic equivariant bifurcation theory and its role in phase transitions;
- Phenomenological and molecular theories based on order parameters, their



Fig. 1: Ubiquitous liquid crystalline order: smectic basmati rice with defects. [1]

microscopic derivation, dependence on particle shapes, symmetries, bifurcations and eigenvalue constraints;

- Atomistic and molecular dynamics simulations of liquid crystal systems;
- Analysis of the Landau – de Gennes Q-tensor theory, its relation to director models, and the contrasting descriptions of defects in these different models;
- Topology and defect structures in liquid crystal colloid mixtures;
- Smectic and chiral structures: focal conic domains and torons;
- Dynamics of liquid crystal flows, well-posedness in director and Q-tensor models, bifurcation analysis of shear flows;
- Liquid crystalline solids, their microstructures, mechanical consequences of their LC defects, and use in elastomeric motors;
- Models of active liquid crystals in biology (in which the constituent particles are self-propelled) and their flows (see Fig. 2).

FACT FILE

No. of participants: 219

Gender Balance:

Male: 178 Female: 41

No. of preprints and papers produced: 29

Rothschild Distinguished Visiting Fellow:
Tom Lubensky

Microsoft Visiting Fellow:
Epifanio Virga

Numerous research projects were initiated, establishing new connections and international collaborations between mathematicians, physicists, chemists, materials scientists and biologists, from starting research students to established researchers.

Programme activities included four very successful one week workshops on different aspects of liquid crystals, one of which was a *Satellite Meeting* at the University of Oxford. An additional one day Turing Gateway meeting brought together mathematicians and representatives of industry producing liquid crystal materials and devices. The British Liquid Crystal Society also held their annual meeting in Cambridge to benefit from the programme, with several participants giving invited lectures. In the area of soft matter there was a significant synergy with the parallel INI programme on *Mathematical Modelling and Analysis of Complex Fluids and Active Media in Evolving Domains*, with a number of mutual talks and a joint workshop session, which enabled a fruitful interaction between the two communities. The Rothschild Distinguished Visiting Fellow was Tom Lubensky (Pennsylvania), and the Microsoft Research Visiting Fellow was Epifanio Virga (Università degli Studi di Pavia).

The programme experimented with and exploited the internet and social media in various ways.

A special effort was made to involve young researchers. A two-day meeting for young researchers was held in which every participant gave a short presentation and had individual mentoring sessions with senior researchers attending the Programme, some of whom gave talks on open problems in the field.

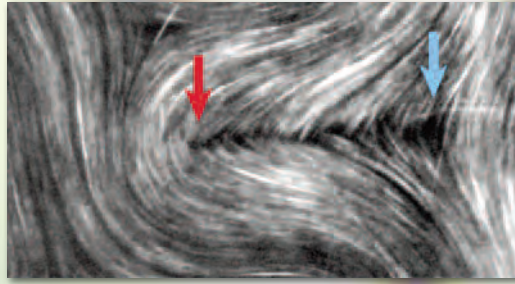

Fig. 2: Biologically related active microtubule liquid crystal domains extend, buckle and internally self-fracture. [2]

The last two weeks of the programme were also organised in conjunction with the I-CAMP 2013 Summer School, in which about 80 young researchers attended an intensive programme of lectures and other activities in Cambridge.

The programme experimented with and exploited the internet and social media in various ways. For example a Remote Poster Session using *Google+Hangout* was held between participants and graduate students and faculty at the Liquid Crystal Institute at Kent State University. The intent was to bring together programme participants with geographically separated students and faculty for real-time face-to-face discussions in small groups using social media, and to assess the ease of setting up and the overall effectiveness of such interactions. This proved very successful, and the graduate students at Kent State who prepared the online posters and related short videos were particularly pleased with the ability to interact with world experts in the field at the INI, who viewed the posters from their offices.

Another innovation was the delivery of two outstanding remote seminars by interactive video-link. The first, by Professor Yuka Tabe (Waseda University, Tokyo), concerned orientational motion and flow due to vapour transport through membranes of chiral liquid crystals. The second, by Professor Nicholas Abbott (University of Wisconsin-Madison), described the remarkable discovery of endotoxin-induced ordering transitions in liquid crystalline droplets, which provides a novel way of detecting this bacterial infection-

signalling chemical, previously only possible by using the blood of horseshoe crabs: given the potential industrial impact of this simple detection scheme, a special invitation to attend the remote seminar was extended to affiliates of the Turing Gateway to Mathematics Initiative.

Finally, an interview with Professor Jerry Ericksen was conducted by video-conference from the University of Oregon (see sms.cam.ac.uk/media/1486552), in which he describes his perspectives on liquid crystals, including the issues he and Frank Leslie faced in their famous work on the continuum theory, together with other aspects of his distinguished career in mechanics.

Together with the frequent viewing of streamed lectures, either in real time or later, these activities are examples of how colleagues, unable to attend in person, were able both to contribute greatly to the scope of the programme and to benefit from it. The archive of videos of lectures from the programme will form an important source of material for researchers in the area which will extend the influence of the programme into the future. However it is hoped to achieve this in a more proactive way by setting up a web-based resource for open problems in the mathematics of liquid crystals, based initially on those problems identified during the programme.

[1] V Narayan, N Menon and S Ramaswamy, "Nonequilibrium steady states in a vibrated-rod monolayer: tetratic, nematic and smectic correlations." *J. Stat. Mech.* (2006) P01005

[2] T Sanchez, DTN Chen, SJ DeCamp, M Heymann and Z Dogic, "Spontaneous motion in hierarchically assembled active matter", *Nature* 491, 431 (2012)

Mathematical Modelling and Analysis of Complex Fluids and Active Media in Evolving Domains

7 January to 5 July 2013

www.newton.ac.uk/programmes/CFM/

Report from the Organisers:

Darryl Holm (Imperial), Karsten Kruse (Saarbrücken), Peter Olmsted (Leeds), Len Pismen (Technion) and Uwe Thiele (Loughborough).



The study of the dynamics of complex fluids and active media in adaptive domains is interdisciplinary and requires a close collaboration between researchers with very different scientific backgrounds. Of the utmost importance are advanced mathematical techniques that are normally developed in close interaction between applied mathematicians and the 'users' in various other scientific fields. Therefore a significant aim of the programme was to establish or

renew communications between scientists from a spectrum of disciplines ranging from geometrical mechanics - where the dissipationless motion of complex fluids is expressed using the combined theory of Lie groups and differential geometry - to the physics of cell locomotion - where the dissipation-dominated motion and development of the cytoskeleton is expressed through models for active fluids. The treatment of adaptive domains incorporated a discussion of many problems related to the motion of various types of two-phase interfaces and three-phase contact lines.

The nonlinear evolution of small amounts of complex liquids or active media bounded by different types of interfaces is currently the subject of intense multidisciplinary research. Mathematical models for a large variety of systems are being derived and analysed in an intense collaboration between applied mathematicians and natural scientists, and applications, e.g. in microfluidics, bio- and nano-technology, are fast transforming the field into one of high importance to several engineering disciplines.

During the programme researchers from the UK, Europe and overseas developed advanced mathematical descriptions of complex fluids and active media in adaptive domains and many collaborations between applied mathematicians and various other communities involved in biophysics, bio-mathematics, soft condensed matter science, fluid dynamics, pattern formation, nano- and microfluidics, and related fields, were initiated.

Topics and open problems that initiated discussions and led to such collaborations include:

- Geometric-mechanical descriptions of complex fluids as micropolar liquids, the Euler–Poincaré approach, and the incorporation of dissipation and interfaces into this framework;
- Gradient dynamics descriptions for interface- and dissipation-dominated layers of complex fluids;
- Microscale molecular dynamics simulations of complex fluids, e.g., drops on solid substrates or membranes, their relation to microscale and mesoscale continuum models, as dynamical density functional theory (see Fig. 1) and hydrodynamic gradient dynamics models, respectively;
- Mathematics of coarse-graining and upscaling techniques in the context of complex fluids, cross-usage of techniques, e.g., coarse bifurcation analysis for microscopic simulators;
- Nonlocal evolution equations, their well-posedness and analysis;

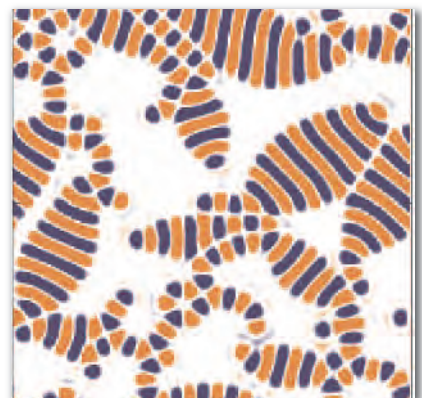

Fig. 1: Understanding soft materials: Localised states obtained through crystallisation of a binary colloidal suspension as modelled through a phase field crystal model [1]

FACT FILE

No. of participants: 202

Gender Balance:

Male: 174 Female: 28

No. of preprints and papers produced: 17

Rothschild Distinguished Visiting Fellow:

Peter Constantin

Microsoft Visiting Fellow:

Yannis Kevrekidis

- Mechanics of living cells, which involves complex problems of modelling an active medium with rheology combining viscoelasticity, anisotropy, and multiphase features, coupled to chemical transformations, diffusion, and active transport (see Fig. 2);
- Mathematical descriptions of the motion of single crawling and swimming cells, bacteria and artificial microswimmers; collective dynamics of microswimmers, dynamics and growth of biological membranes, biofilms and tissues;
- Equilibrium and non-equilibrium behaviour of complex and active fluids, the relevance of the description of active media to classical kinetic equations;
- Asymptotic and numerical methods for kinetic equations describing complex fluids, the role and description of defects, topological phases;
- Interactions with boundaries of complex fluids;
- Interface dynamics for complex fluids, the coupling of internal degrees of freedom and interface motion, e.g., for liquid crystals, nanoparticle suspensions and polymer solutions; drying and crystallisation fronts, patterned deposition from moving fronts;
- Shear-induced transitions in complex fluids, shear-banding, micro-structural rearrangement. Control through boundary conditions.

The list illustrates how complex fluids with interfaces are challenging, not only with respect to the development of mathematically and thermodynamically consistent models, but also with respect to the analysis of behaviour involving the interplay of instabilities that trigger hierarchical structure formation processes, the development of singularities, and the dynamics of emerging defects. By addressing such problems, the programme at the INI has resulted in a cross-fertilisation between fluid mechanics and mathematical theory that will drive both the development of perturbation methods and other analytical tools, and lead to an understanding of related physical phenomena.

These challenges were successfully tackled through a combination of many seminars, crash courses, informal discussion meetings, workshops and collaborations that involved participants, from world leading experts to junior faculty, postdocs and PhD candidates. During the first two months the programme enjoyed multifaceted interactions with the parallel INI programme *The Mathematics of Liquid Crystals*. The overlap of interests resulted in joint activities, from common seminars and discussions, shared participants, exchange of seminar speakers and two workshops (*Dynamics of Active Suspensions, Gels, Cells and Tissues* and *Liquid Crystal Defects and their Geometry, Active and Solid Liquid Crystals*) that were held in parallel with shared sessions on subjects of common interest, in particular, relating to active soft matter. These interactions were fruitful for both communities and increased the outreach of both programmes.

In addition to the ongoing seminar programme involving fellows and participants, the wider scientific community was involved through an embedded summer school on *Mathematical Approaches to Complex Fluids*. This two-week event attracted early career researchers and included lectures on different approaches to complex fluids and active media. The combination of short contributions and longer instructional courses allowed early career researchers to better integrate mathematical modelling and non-equilibrium, nonlinear, and soft matter science into their research fields. Early career researchers obtained feedback on their research posters from leading experts.

The programme has resulted in collaborations and research projects that will shape the field for some time to come. Most of the lectures and seminars were streamed live and attended by colleagues worldwide who could not attend in person. The resulting video archive will prove to be a very valuable source of knowledge and inspiration that will ensure its continuing influence. We believe that the programme has been instrumental in overcoming the incipient fragmentation of the field and consequently has opened opportunities to trigger major future advances.

[1] MJ Robbins, AJ Archer, U Thiele, and E Knobloch. *Modelling fluids and crystals using a two-component modified phase field crystal model*. Phys. Rev. E, 85:061408, 2012. doi:10.1103/PhysRevE.85.061408.

[2] K Doubrovinski and K Kruse. *Cell motility resulting from spontaneous polymerization waves*. Phys. Rev. Lett., 107:258103, 2011. doi:10.1103/PhysRevLett.107.258103.



Fig. 2: Cell motility: Snapshots of spontaneous actin waves in domains with dynamic boundaries modelled through a mesoscopic description of treadmilling actin filaments. One- and two-armed spirals and a breather. Warm colours represent high, cold colours low actin densities [2]

Follow-up Meetings

The Institute is constantly seeking ways to extend and add value to its programmes. To this end, *Follow-up Meetings* are short events which compliment full programmes that were held some years earlier. These are proving increasingly popular with programme organisers because of how they provide an effective way to strengthen collaborations started during the original programmes and are particularly beneficial because the true implications of results may emerge from developments only years after a programme has finished. *Follow-up Meetings* take place either at the Institute or at suitable venues anywhere in the UK. Short reports from the organisers on the *Follow-up Meetings* that have taken place this year are shown below. Details of all *Follow-up Meetings* to date can be found on the web at www.newton.ac.uk/follow-ups.

Stochastic Partial Differential Equations

10–14 September 2012

Organisers: Zdzislaw Brzezniak (York), David Elworthy (Warwick), Martin Hairer (Warwick), Michael Röckner (Bielefeld), Panagiotis Souganidis (Chicago) and Roger Tribe (Warwick).

Stochastic Partial Differential Equations are used to model physical systems subjected to influence of internal, external or environmental noise or to describe systems that are too complex to be described deterministically, e.g. a flow of a chemical substance in a river subjected by wind and rain, an airflow around an airplanes wing perturbed by the random state of the atmosphere and weather, a laser beam subjected to turbulent movement of the atmosphere, spread of an epidemic in some regions and the spatial spread of infectious diseases.

For this *Follow-up Meeting* the key workers were invited from the 2010 programme in those areas which were under active development to review the progress made and to set out the current main open problems for exploration. These included large deviations for infinite dimensional systems; calculus on infinite dimensional spaces; stochastic models for hydrodynamics; applications of Malliavin calculus; models with non-Gaussian drivers; specific applications such as stochastic models for ferro-magnetism and non-linear photonics. In addition the workshop explored new directions that have opened up

since the 2010 programme, some of which were initiated at the INI.

The workshop exceeded expectations and the reaction from the mathematical sciences community was overwhelming, bringing together people working in the field and many new collaborations being formed. The field has become more visible within the whole discipline of mathematics, and also to other sciences which are prospective fields of applications. Several future projects are being planned, among them a special semester at the MSRI in Berkeley.

Mathematics and Physics of Disordered Systems

17–21 September 2012

Organisers: Yan Fyodorov (Queen Mary, London), Ilya Goldsheid (Queen Mary, London), Thomas Spencer (Princeton) and Martin Zirnbauer (Cologne).

Following up on the 2008 programme *Mathematics and Physics of Anderson localization: 50 Years After* this meeting explored a variety of approaches to the study of classical and quantum models of random media and to promote a dialogue among a diverse group of 47 participants representing theoretical physics, probability and analysis.

Historically, Schrödinger operators with random potential were among the first models which reflected Anderson localization. Related topics addressed during the workshop included multi-fractal properties of eigenstates, relations between quantum and classical dynamics,

topological insulators, and the quantum Hall effect. Results on extreme value statistics of disordered energy landscapes, polymers in disordered media, random walks in random environment and random band matrices were also presented.

The workshop received financial support from the DFG (German National Science Foundation).

Highlights of the meeting include C Sabot and P Tarres explained the equivalence between the vertex reinforced jump process and the supersymmetric (SUSY) hyperbolic σ -model analysed a few years earlier by M Disertori, T Spencer & MR Zirnbauer. A Mirlin reported on joint work with I Gruzberg, A Ludwig, and MR Zirnbauer on the classification and symmetry properties of scaling dimensions at Anderson transitions.

J Keating described his joint work with YV Fyodorov on the statistics of maxima of characteristic polynomials of random matrices and related properties of the Riemann zeta-function. There were several talks (by E Bolthausen, N O'Connell, K Khanin, and P Le Doussal) on polymers in a random environment and the Kardar–Parisi–Zhang equation, using the complementary methods of replicas and integrable systems to study these systems.

The themes of the meeting are further pursued in the Simons symposium on the Kardar–Parisi–Zhang equation (2013), the IAS programme *Non-equilibrium Dynamics and Random Matrices*

(2013–14), and the upcoming INI programme *Periodic and Ergodic Spectral Problems* (2015). Many of the participants who attended the meeting are actively engaged in organising these programmes. In conclusion, the workshop succeeded in promoting an active dialogue between mathematical and theoretical physics, which is essential for fundamental progress in the areas of common interest.

**Energy Systems Week:
Management of Variability and
Uncertainty in Energy Systems
22–26 April 2013**

Organisers: Stan Zachary (Heriot-Watt), David Lenaghan (National Grid plc), Robert Leese (Industrial Mathematics KTN), Andrew Richards (National Grid plc), Sergey Foss (Heriot-Watt), James Cruise (Heriot-Watt) and Chris Dent (Durham).

Following on from the Spring 2010 programme *Stochastic Processes in Communication Sciences*, and the one-week *Energy Systems* workshop which formed part of that programme, this meeting focused on identifying where and how mathematics can contribute to the pressing system management problems now facing the energy industry.

**2nd Conference on Dense
Granular Flows
1–5 July 2013**

Organisers: Ricky Wildman (Nottingham), Jim McElwaine (Durham), Yoël Forterre (Polytech Marseille), Nico Gray (Manchester), Christine Hrenya (Colorado) and Jonathon Huntley (Loughborough).

This meeting followed on from a workshop with the same name held in January 2009 and the INI *Granular and Particle Laden Flows* programme hosted by INI in 2003.

The objective was to interface the two ends of the particulate flow spectrum – those working to understand the fundamentals of granular flows and those attempting to control particulate flows in an

industrial setting - to develop solutions to the complex problems presented by dense granular flows.

Themes included dense granular flow, biological systems, self-propelled particles and geological flows, exploring new developments in theoretical analysis and experimental techniques.

**Discrete Integrable Systems
8–12 July 2013**

Organisers: Rod Halburd (UCL), Frank Nijhoff (Leeds) and Reinout Quispel (La Trobe).

The 6-month programme *Discrete Integrable Systems* held at the Isaac Newton Institute in 2009 was very well received. A *Follow-up Meeting* was considered highly desirable to cover the many advances and extensions of ideas that had occurred in the field in the since then.

It had 73 participants including some of the participants from the original programme together with many new people. Some researchers had only recently started to study discrete integrable systems. In particular, Vincent Caudrelier (City University, London) reported that the meeting was extremely helpful, both for him and for his PhD student, Cheng Zhang, to become involved in the community of discrete integrable systems and it helped them to take up research in this area. Cheng has

now completed his viva and has just got a post-doctoral position in Leeds with Frank Nijhoff.

Many talks at the meeting built on ideas that had first been developed during the original programme. For example, one outcome of the original programme in 2009 was the development by Lobb and Nijhoff of a novel variational formalism for integrable lattice systems based on Lagrangian multiforms. Four talks (SB Lobb, F Nijhoff, YB Suris and S Yoo-Kong) and one poster (R Boll) described significant developments in this area. Other results included the construction of first integrals for reductions of integrable lattice equations. Another was the development of generalised symmetry methods for discrete equations.

Subsequent discussions have led to plans to run a short meeting at UCL in early 2014 to explore both integrable and non-integrable aspects of such equations. In particular R Halburd and P Hydon will explore symmetry properties of such equations. One purpose of the meeting will be to explore applications and to connect with end users of differential delay equations. Discussions at the meeting also led to the decision to run regular half-day meetings in the greater London area on discrete integrable systems.



Participants at the Follow-up Meeting
'Stochastic Partial Differential Equations'

Serving the UK Community



Michael Singer
Chair of Correspondents

I was appointed Chair of Correspondents only in January but already I have a strong sense of the importance of the Network of Correspondents to the work of INI. Originally it was developed as a channel through which INI could tell universities, mainly their mathematics departments, about INI activities. Then, about five years ago the Correspondents' terms of reference were extended to include an advisory role, to facilitate a proper dialogue between INI and anyone with an interest in INI activities. Thus, with my predecessor Caroline Series in the Chair, INI expanded the Network to include individuals in research

institutes across many disciplines and sought new opportunities for better communication between INI and its interest groups. Currently Correspondents receive the Correspondents' Bulletin, INI Newsletter and Annual Report by email but I believe there are now even better ways to exchange information with INI, for example via using social networking. The newly designed web site, which I understand is in the offing, will facilitate this. I am also interested in supporting the new Turing Gateway to Mathematics (TGM) project and its effort to recognise and facilitate the impact of the mathematical sciences beyond their usual boundaries.

I am looking forward to working with the Director (John Toland), Deputy Director (Christie Marr), the Librarian and Information Officer who looks after communications (Sara Wilkinson), and the Knowledge Transfer Facilitator who is managing the TGM (Jane Leeks), to develop these ideas and to challenge and support INI across a range of issues.

Annual Meeting of Correspondents

This year's Correspondent's Day was held at INI on Monday 10th June 2013. In the Welcome and Introduction, Chair of Correspondents, Michael Singer (UCL), identified actions and outcomes following comments and suggestions made at the 2012 meeting. Issues of particular concern to Correspondents in 2012 had been support for early career researchers and for women in mathematics, and the opportunities created by social media. The Chair informed Correspondents that INI had held 5 one-day events for early career researchers in March 2013 and that funding restrictions for students had recently been relaxed by EPSRC. He commented that INI had revised and updated its *Gender Balance Action Plan* and that it had hosted the 2013 LMS Women in Mathematics Day. Finally, INI has embraced social media and has approximately 1000 likes on Facebook and 900 followers and 200 tweets on Twitter. He reported that the *Mathematics of Liquid Crystals* programme had recently used Google+ Hangout to facilitate a virtual poster session between INI programme participants and students and faculty at the Liquid Crystal Institute, Kent State University, Ohio.

The Correspondent's Day lecture entitled *Science and the Challenge of Evidence-Based Policy* was given by Christl Donnelly, Professor of Statistical Epidemiology at the MRC Centre for Outbreak Analysis and Modelling in

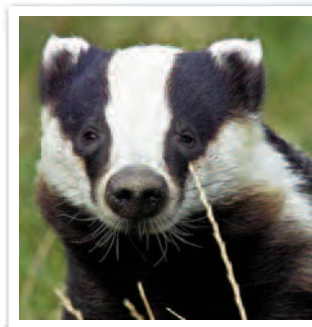

the Department of Infectious Disease Epidemiology at Imperial College London. She was a member of the 1997 Krebs Review Committee examining the links between bovine tuberculosis and badgers, and the Deputy Chair of the

Independent Scientific Group on bovine tuberculosis from 1998 to 2007. She also helped to advise policymakers about BSE/variant CJD, FMD, SARS and pandemic influenza. In this talk she discussed the relationship between science and policy and in particular the diverse policies put in place across the UK for tackling the spread of TB following a randomized badger culling trial on the spread of TB and the impact of control measures put in place during the 2001 Foot and Mouth outbreak.

Correspondents were invited to attend the Rothschild Seminar given by Peter Constantin, William R. Kenan Jr. Professor in the Department of Mathematics at Princeton University, and Rothschild Distinguished Visiting Fellow on the INI programme *Mathematical Modelling and Analysis of Complex Fluids and Active Media in Evolving Domains*.

The table opposite shows the current list of Newton Institute Correspondents both in UK HEI's and in learned societies, commercial organisations and research institutes.

Newton Institute Correspondents

Aberdeen	A Sevastyanov	London, King's College	K Rietsch
Aston	D Saad	London Metropolitan	P Calay
Bath	A Jarai	London, Queen Mary	PJ Cameron
Belfast, Queens	AW Wickstead	London, Royal Holloway	J Crampton
Birmingham	CW Parker	London School of Economics	J van den Heuvel
Bradford	A Vourdas	London, University College	ER Johnson
Brighton	PJ Harris	Loughborough	AP Veselov
Bristol	F Mezzadri	Manchester	M Prest
Brunel	I Smolyarenko	Napier	T Muneer
Cambridge	N Dorey	Newcastle	CF Barenghi
City	O Kerr	Nottingham	S Coombes
Dundee	G Hornig	Open	UG Grimm
Durham	O Hryniv	Oxford	G Nicholls
East Anglia	S Stevens	Plymouth	C Christopher
Edinburgh	A Bayer	Portsmouth	AD Burbanks
Essex	DB Penman	Reading	A Moiola
Exeter	A Gilbert	St Andrews	DG Dritschel
Glasgow	C Athorne	Salford	RD Baker
Greenwich	K Parrott	Sheffield	K Mackenzie
Heriot-Watt	JR Cruise	Southampton	CJ Howls
Hertfordshire	S Kane	Staffordshire	BL Burrows
Huddersfield	A Crampton	Stirling	R Norman
Hull	JW Elliott	Surrey	M Wolf
Keele	JJ Healey	Sussex	M Chlebik
Kent	PA Clarkson	Ulster	M McCartney
Lancaster	S Power	Wales (Aberystwyth)	RJ Douglas
Leeds	A Pillay	Wales (Cardiff)	KM Schmidt
Leeds Metropolitan	E Guest	Wales (Swansea)	T Brzezinski
Leicester	F Neumann	Wales (WIMCS)	SA Williamson
Liverpool	V Goryunov	Warwick	X Li
Liverpool John Moores	PJG Lisboa	West of England	K Henderson
London, Imperial College	K Christensen	York	N MacKay

British Computer Society	B Mitchell	Microsoft Research Group	CM Bishop
British Geological Survey	RM Lark	Nat. Ocean. Centre, Liverpool	J Polton
Edinburgh Mathematical Soc.	TH Lenagan	Nat. Ocean. Centre, Southampton	M Srokosz
EPSRC	C Tansley	NERC	N Garnett
ESRC	S Werts	OCISB	R Baker
European Bioinformatics Institute	C Brooksbank	OR Society	R Hibbs
ICMS	K Ball	Pirbright Institute	D Schley
Institute of Actuaries	K McIver	Rothamsted Research	M Semenov
IMA (Academic)	P Glendinning	Royal Academy of Engineering	J McWhirter
IMA (Organisational)	D Youdan	Royal Society	M Taylor
Institute of Physics	R Behrend	Royal Statistical Society	S Olhede
John Innes Centre	S Maree	Rutherford Appleton Laboratory	T Rees
LMS	U Tillmann	STFC	S Verth
Mathematical Association	C Ogden	Schlumberger	P Hammond
Met Office	MJP Cullen	Smith Institute	C Cawthorn

Institute Activities

Seminars on the Web

All Institute seminars and lectures are, with the permission of speakers, advertised in advance, streamed live and made available on the web in perpetuity. Thanks to a one-off equipment grant from EPSRC, the Institute has state-of-the-art streaming and video-conference facilities.

In addition to broadcasting its own lectures, the Institute uses its facilities to provide distinguished scientists who are unable to attend in person with the opportunity to lecture during programmes or workshops. These interactive sessions are held in the Institute's lecture theatre, with question and answer sessions between the audience and the speaker at a different location.

The library of online seminars is a significant scientific resource. During 2012/13 within the six programmes covered by this report and including other events over 900 seminars were added to the collection.

There is significant evidence, both statistical (see www.sms.cam.ac.uk/institution/INIMS/statistics) and anecdotal, that in the UK and elsewhere people monitor INI activity and attend seminars remotely when they cannot participate.



Seminars in the UK

Visiting Fellows on Newton Institute programmes are strongly encouraged to visit other institutions within the UK during their stay at the Institute, and 125 visitors did so during 2012/13 delivering a total of 204 seminars in 40 different institutions. To promote this activity, the Institute covers on request the travel costs within the UK for any overseas Fellow.

Lists of future participants, with dates of their visits to the Institute, can be found on the individual programme web pages. In addition, the Institute has set up a register, with titles of topics, of those Fellows who are willing to travel to other UK institutions to give seminars. Correspondents are urged to ensure that organisers of local seminar series know about and consult this register when planning their schedule of speakers. Potential speakers may be contacted directly using the details listed in the register, which can be found at www.newton.ac.uk/programmes/speakers.html.

Alternatively, advice on suitable speakers may be obtained from the organisers of any Institute programme via the Institute.



Susan Friedlander delivers a lecture as part of the 'Topological Dynamics in the Physical and Biological Sciences' programme

Short Visits

Any researcher associated with a UK University, academic institution or R&D group in industry or commerce may visit the Newton Institute for up to two days without an invitation, in order to attend seminars or to work with colleagues. We ask that reception@newton.ac.uk is emailed in advance to assist us with planning. Further details are at www.newton.ac.uk/shortvisits.html.

Follow-up Meetings

As discussed in pages 16–17 and as stated in the Institute's Scientific Policy Statement, it is intended that each programme will have long-term impact well beyond the programme itself in terms of breakthroughs, new research directions and collaborations. The Institute, therefore, arranges short *Follow-up Meetings* some years after programmes end, whenever the original organisers are enthusiastic.

Satellite Meetings

The Institute encourages organisers of 4- or 6-month programmes to cooperate with local organisers in holding *Satellite Meetings* at UK Universities and institutions outside Cambridge. *Satellite Meetings* are organised on themes related to an Institute programme, and involve a significant number of the longer-stay overseas participants who are visiting the Institute at the time. They also, crucially, draw in and involve UK mathematicians and scientists who might not otherwise be able to participate substantially in the Institute programme; and they enable the expertise of the Institute's overseas participants to be shared more widely within the UK.

Costs for *Satellite Meetings* are shared between the Institute and the host institution and the Institute typically contributes £15,000 (excluding the overseas travel costs of Institute participants, which are covered separately).

The Institute is keen to continue to expand the geographical range of *Satellite Meeting* locations. Institutions interested in holding a meeting should contact either the organisers of the relevant programme or the Deputy Director.

Future *Satellite Meetings* are planned at Reading and Warwick. Further details are available at www.newton.ac.uk/events.html.

Distribution of Satellite Meetings

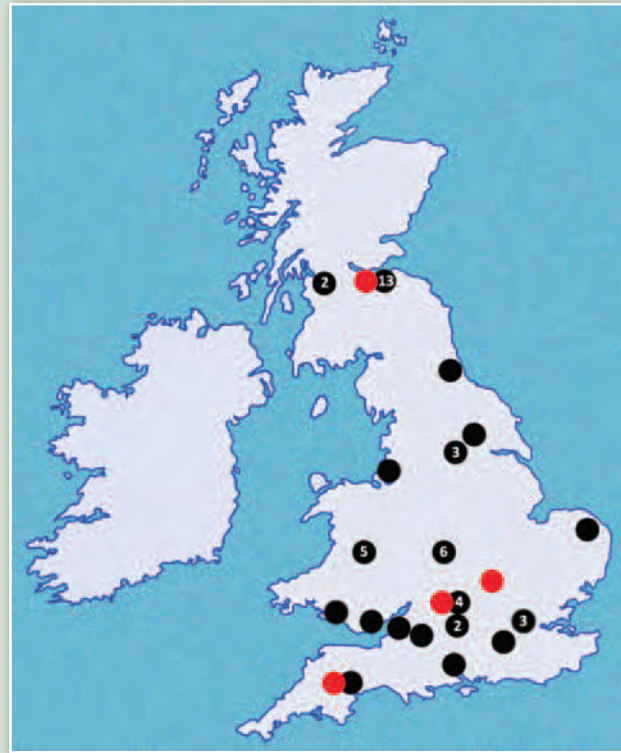

● Planned ● Held

Numbers indicate the quantity of events held or planned where greater than one.

Junior Membership

The Institute recognises that early career researchers have much to contribute to, and gain from, Institute programmes and events. In order to maximise the information available to them, and to facilitate their involvement in Institute activities by offering additional funding opportunities, there is a special scheme for Junior Membership of the Newton Institute. To be eligible you must be either a Research Student or within 5 years of having received your PhD (with appropriate allowance for career breaks), and you must work or study in a UK University or a related research institution. Those wishing to join the scheme should consult the Institute's web site at www.newton.ac.uk/junior.

Members will receive regular advance information regarding programmes, workshops, conferences and other Institute events. The Institute also makes available some of its general funds specifically to support early career researchers taking part in Institute activities. Members may apply for grants from

these funds. Types of involvement supported include attendance at workshops, conferences, etc., and visits of up to two weeks to work or study with longer-stay participants in the Institute's research programmes.

The Institute registered 43 new Junior Members during 2012/13; the current total is 728 as at the end of July 2013.



C.M. Palmer

Management and Statistical Reports



Howard Covington
*Chair of the
Management
Committee*

In March this year the Institute’s research council funding was renewed for a further four years. Our funding proposal was strongly supported by eminent mathematical scientists from around the world. Peer reviewers scored it 35 out of 36, giving quantitative recognition to the excellence consistently achieved in our research programmes.

Having a flourishing world-class visitor research institute is an essential ingredient in being a leading mathematics research nation. INI’s programmes contribute significantly to expanding the boundaries of mathematical knowledge and driving applications in

science, business and industry. It is highly encouraging that the Institute’s financing is secure in the medium term.

The Institute must, however, recognise the uncertainty of research funding in the longer term. The Management Committee and the Development Board strive to diversify INI’s funding. I would like to take this opportunity to thank all of our donors who contribute so much in supporting INI’s vital work for the mathematical sciences in the UK. The Development Board will continue to work with the Cambridge University Development Office to fund the world-class mathematicians who participate in our programmes.

The Institute seeks continually to streamline its operations. Following a formal review of IT services, we are vigorously updating our administrative processes. In future these will be based on a new database and interactive web site. Subject to the physical limitations of our office space this should release personnel to support a broadening of activities in cutting-edge research and engagement with the multiplicity of applications of mathematics.

Management Committee

Membership of the Management Committee at 31 July 2013 was as follows:

Name	Affiliation	End of Service
Sir John Ball FRS FRSE	Chair of Scientific Steering Committee	31 Dec 2013
Professor Bill Bruce	London Mathematical Society	31 Dec 2014
Mr Howard Covington (Chair)	General Board	31 Dec 2014
Professor Peter Haynes	Head, DAMTP, University of Cambridge	–
Dr Phillippa Hemmings	EPSRC	31 Dec 2014
Professor Martin Hyland	Head, DPMMS, University of Cambridge	31 Dec 2013
Professor Robin Langley	Council of the School of Technology	31 Dec 2014
Dr Joan Lasenby	Trinity College, Cambridge	31 Dec 2014
Professor Nick Manton FRS	St John’s College, Cambridge	31 Dec 2014
Dr Christie Marr (Secretary)	Deputy Director, Isaac Newton Institute	–
Professor Michael Singer	Chair of Correspondents	31 Dec 2014
Professor Andy Parker	Council of the School of Physical Sciences	31 Dec 2014
Professor John Toland FRS FRSE	Director, Newton Institute	–

The Management Committee is responsible for overall control of the budget of the Institute and for its financial planning. The Director is responsible to the Management Committee, which provides essential advice and support in relation to fund-raising activities, employment of the staff of the Institute, appointment of the organisers of programmes and general oversight of Institute activities. Its aim is to facilitate to the fullest possible extent the smooth and effective running of the Institute’s programmes and all related activities.

Programme Participation

A total of 1,726 visitors was recorded for 2012/13.

This includes 400 Visiting Fellows (who have allocated offices) and 126 Programme Participants (other long-term participants). Within the six programmes during the year 22 workshops (periods of intense activity on specialised topics) which serve to widen UK participation in programmes attracted a further 626 visitors (i.e., those not already attending the programme).

In addition to workshops, the Institute from time to time arranges less formal special academic meetings as

well as talks for the general public, so further opening up the activities of the Institute. More than 574 visitors attended such events and took part informally in Institute activities or attended *Satellite Meetings* and *Follow-up Meetings*.

In all, 1126 seminars were given at the Institute during the year. The Institute also funds visits by overseas programme participants to other UK institutions to give seminars (see page 20), and 204 such seminars took place.

Programme	Visiting Fellows	Mean stay (days)	Programme Participants	Mean stay (days)	Workshop Participants
<i>Spectral Theory of Relativistic Operators</i>	33	17	16	14	21
<i>Topological Dynamics in the Physical and Biological Sciences</i>	76	47	10	102	187
<i>Multiscale Numerics for the Atmosphere and Ocean</i>	69	48	42	29	94
<i>Grothendieck–Teichmüller Groups, Deformation and Operads</i>	73	36	21	47	89
<i>The Mathematics of Liquid Crystals</i>	68	66	27	55	124
<i>Mathematical Modelling and Analysis of Complex Fluids and Active Media in Evolving Domains</i>	81	32	10	40	111
	400	43	126	42	626

The pie charts below show the percentages of Visiting Fellows, Programme Participants and Workshop Participants broken down by country of residence:

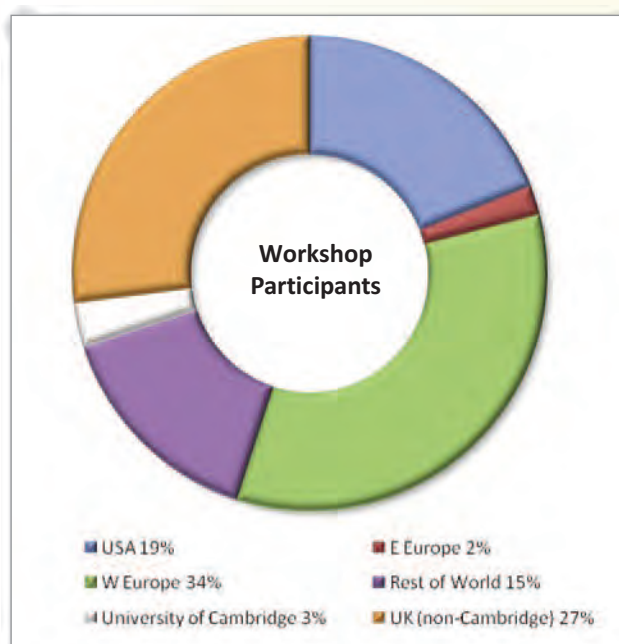
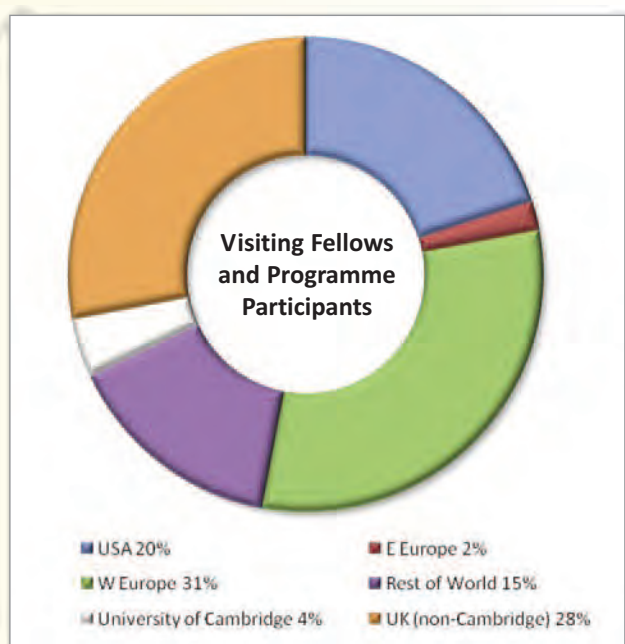

The following chart summarises the total participation figures since the Institute began:

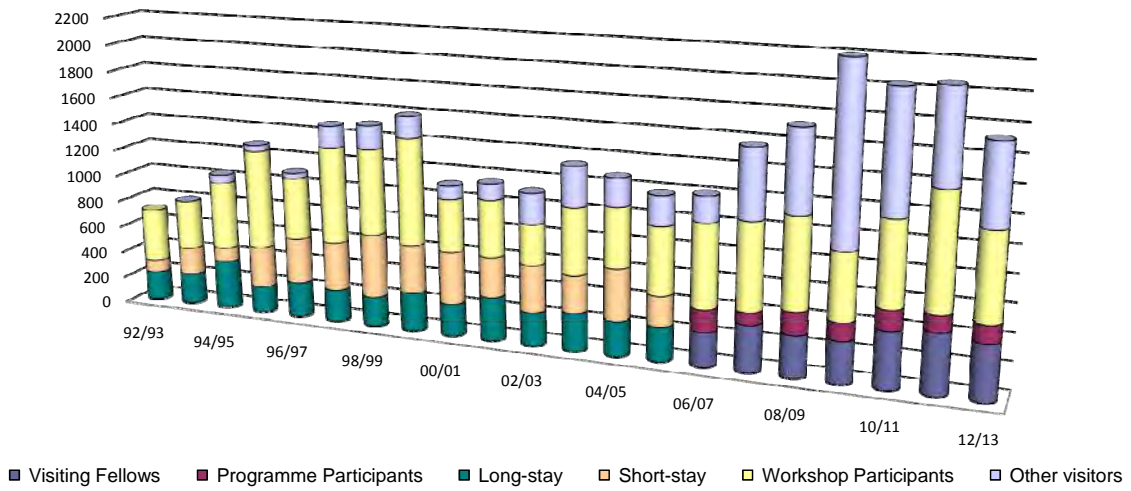

The chart below summarises the total number of person-days for Visiting Fellows and Programme Participants combined, *excluding* Workshop Participants.

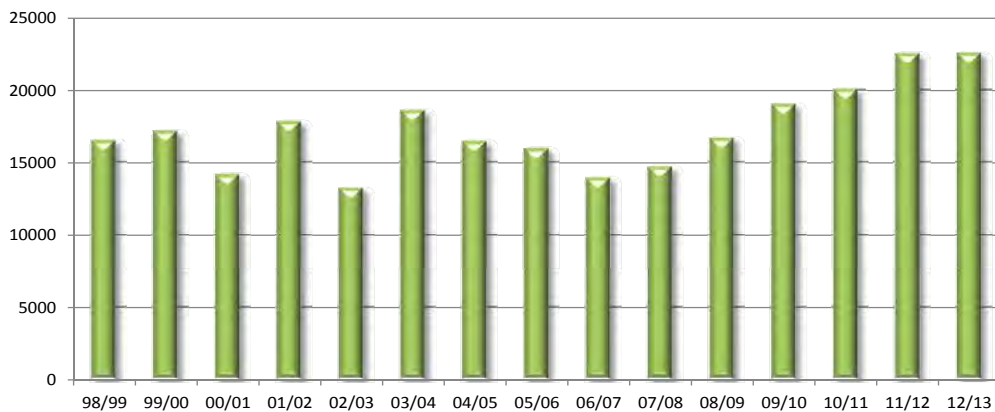

The numbers of all Visiting Fellows, Programme Participants *and* Workshop Participants combined in 2012/13 are shown below, by age and gender:

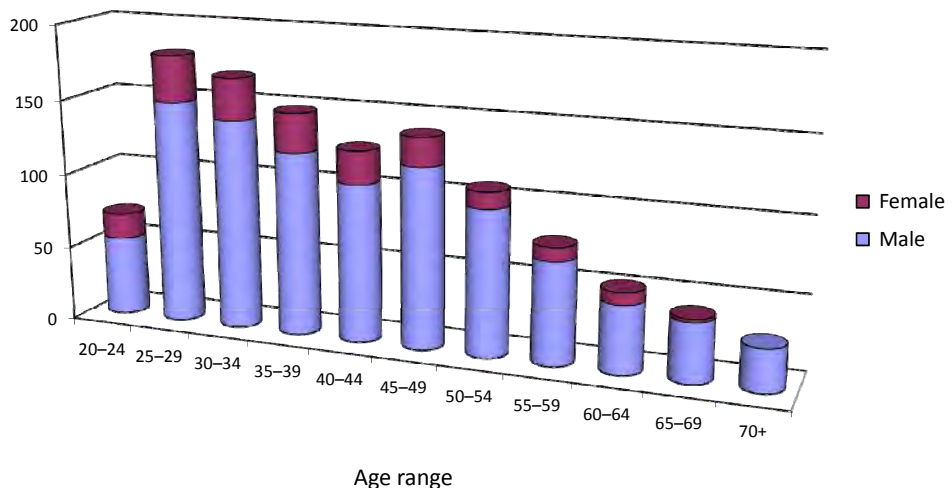

The statistics presented on this page relate only to visitors whose home institutions are in the UK: overseas visitors data are not included.

The age range and gender balance of all Visiting Fellows, Programme Participants and Workshop Participants from UK institutions in 2012/13 are illustrated below:

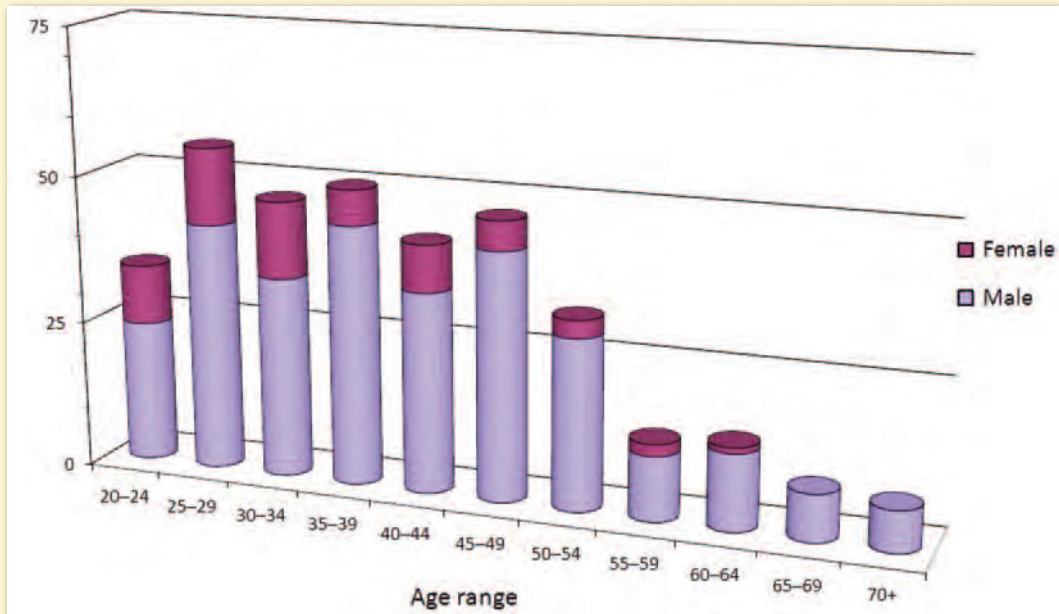

The following diagrams indicate the academic status and geographical distribution of all Visiting Fellows, Programme Participants and Workshop Participants from UK institutions during 2012/13:

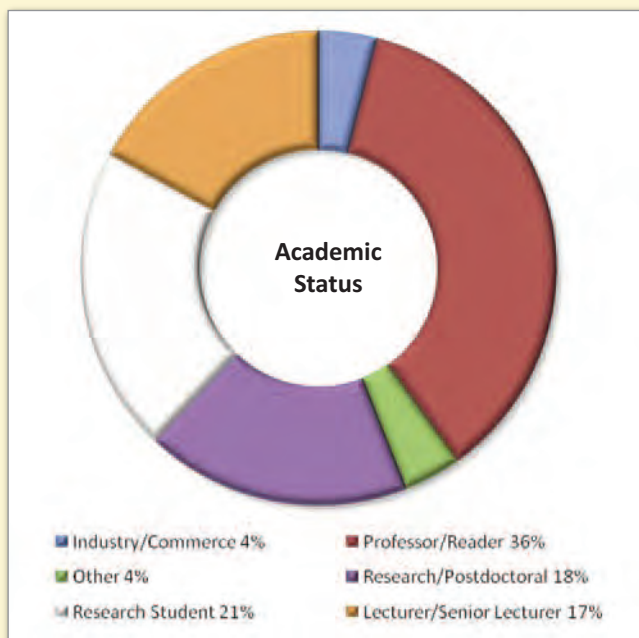

More detailed statistics, including visit dates, home institutions, seminars given and papers written are shown in the Appendices, available at www.newton.ac.uk/reports/1213/appendices.html

Finances

Accounts for July 2012 to August 2013 (Institute Year 21)

	2011/12 Year 20 £'000	2012/13 Year 21 £'000
Income		
Research Grants and Contracts ¹	1,954	2,130
Contribution from the University of Cambridge ²	479	492
Donations ³	98	72
Additional Workshop Income	204	180
Endowment and Investment Income ⁴	161	181
Net Housing Surplus ⁵	66	160
Other Income	36	12
Total Income	2,998	3,227
Expenditure		
Staff Costs	696	670
Travel and Subsistence ⁶	960	1,126
Workshop Expenditure	483	352
Other Institute Activities ⁷	49	31
Other Operating Expenses ⁸	161	119
Overheads paid to University ⁹	463	427
Total Expenditure	2,812	2,725
Surplus / (Deficit)	186	502

Notes to the Accounts

1. Research Grants and Contracts. The income breaks down as follows:

EPSRC Salaries	360	323
EPSRC Travel and Subsistence	962	1,170
EPSRC Workshop Income	261	248
EPSRC Other Costs	22	32
EPSRC Estates and Indirect Income	262	273
Leverhulme Trust	82	84
STFC	5	0
Total	1,954	2,130

2. Contribution from the University of Cambridge. The amounts received break down as follows:

Rothschild Visiting Professorships (drawdown)	15	23
Rothschild Mathematical Sciences (income)	103	105
Contribution Towards Institute Operating Costs	354	358
SRIF, HEIF, CIF, HEFCE Funding	7	6
Total	479	492

The University also provides the main and Gatehouse buildings and pays for all gas, electricity and rates, which have not been included.

3. Donations. A total of £319k received via the Cambridge University Development Office was capitalised and is not included in this figure.

Garfield Weston Foundation	16	7
London Mathematical Society	27	27
Microsoft	30	28
PF Charitable Trust	23	7
Cambridge Philosophical Society	2	3
Total	98	72

4. Endowment and Investment Income. Income received from the Newton Trust fund, the Anonymous Donation Endowment, reserves and deposits.

5. Net Housing Costs.

Income	689	835
Expenditure	623	675
Total	66	160

6. Travel and Subsistence. Expenditure incurred by Programme Visitors including Junior Members.

7. Other Institute Activities. These costs relate to *Open for Business* and fundraising activities as well as expenses from meetings of the Institute's committees, Institute Correspondents, programme organisers, and the travel expenses of overseas participants who visit other UK institutions to give seminars during their stay.

8. Other Operating Expenses.

Building maintenance	31	41
Catering	30	18
Consumables	19	16
Computing and Audio Visual	60	29
Equipment and Furniture	5	5
Library	5	6
Publicity	11	4
Total	161	119

9. Overheads Paid to University. Includes Estates and Indirect costs on grants and overheads on Trust Funds.

Grants and Donations August 2012 to date

In addition to substantial funding from the Engineering and Physical Sciences Research Council, the Institute is indebted for continuing support from the Cambridge Philosophical Society, the Leverhulme Trust, the London Mathematical Society, PF Charitable Trust, NM Rothschild and Sons, and the University of Cambridge.

We are very grateful to the following organisations for their specific support during the year: the Biochemical Society, the Biotechnology and Biological Sciences Research Council, Clay Mathematics Institute, Deutsche Forschungsgemeinschaft (DFG), the Economic and Social Research Council, European Research Council, the Garfield Weston Foundation, GLC Charitable Trust (with special thanks to Lawrence and Rosemary Staden), Henderson Global Investors, John Templeton Foundation, Julian Schwinger Foundation, International Union of Theoretical and Applied Mechanics (IUTAM), Lazard Asset Management – UK, Microsoft Research Cambridge, the National Environmental Research Council, the Science and Technology Facilities Council and the Turner–Kirk Charitable Trust.

Individuals gave generously in support of our activities: Elena Ambrosiadou, Michael Astor, Iain Bratchie, David Chillingworth, Richard Clarke, Howard & Veronika Covington, Thomas W Cusick, Mrs Ann and the late Professor Roy Garstang, Clive Humby & Edwina Dunn, Dr Jonathan Hodgson, Steve Mobbs, Tracey Olsen, Richard Saldanha, Sachin Shende, Ian Simm, Simon Yun-Farmbrough, David & Elizabeth Wallace, Mark Williams as well as donations from individuals who prefer to remain anonymous.

Cumulative Financial Grants and Donations above £10,000

(listed in order of cumulative value)

SERC/ EPSRC/ PPARC/ STFC/ NERC/ BBSRC/ ERSC	David and Elizabeth Wallace
Trinity College (Isaac Newton Trust)	Deutsche Forschungsgemeinschaft
NM Rothschild and Sons	TSUNAMI
University of Cambridge	Daiwa Anglo–Japanese Foundation
European Union	BNP Paribas
Leverhulme Trust	Anonymous Donation
Hewlett–Packard	Hamish Maxwell
Anonymous Donation	Office of Naval Research
Dill Faulkes Foundation	European Science Foundation
St John’s College	Emmanuel College
NATO	Jesus College
CNRS	Medical Research Council
London Mathematical Society	Royal Commission for the Exhibition of 1851
Rosenbaum Foundation	Schlumberger
PF Charitable Trust	British Aerospace
Clive Humby and Edwina Dunn	Rolls Royce
Garfield Weston Foundation	Thriplow Trust
Microsoft Corporation/ Microsoft Research	Autonomy Systems Ltd.
Clay Mathematics Institute	British Gas
Henderson Global Investors	DERA
Howard and Veronika Covington	Magnox Electric
GLC Charitable Trust (Lawrence and Rosemary Staden)	Paul Zucherman Trust
John Templeton Foundation	Steve Mobbs
Sun Microsystems inc.	William Craig
Apple Computers Ltd.	Nomura Corporation
Gonville and Caius College	Bank of England
Prudential Corporation plc	Michael Astor
David Harding Foundation	Iain Bratchie
Turner–Kirk Charitable Trust	European Molecular Biology Organisation
Institute of Physics	Elena Ambrosiadou
National Science Foundation	Applied Probability Trust
Wellcome Trust	Benfield Greig
Met Office	Trinity College
Nuffield Foundation	Unilever
Cambridge Philosophical Society	



LONDON
MATHEMATICAL
SOCIETY





A soap film spanning a twisted wire loop that makes two complete turns can take the form of a Möbius strip. Untwisting the wire leads the soap film to jump from one-sided to two-sided form. A twist localised near the wire boundary persists after the jump, as shown in this image. Image courtesy of RE Goldstein, AI Pesci and HK Moffatt (DAMTP, University of Cambridge) and RL Ricca (Milano-Bicocca) from the programme *Topological Dynamics in the Physical and Biological Sciences*.

Isaac Newton Institute for Mathematical Sciences

20 Clarkson Road, Cambridge, CB3 0EH, UK

tel: +44 (0) 1223 335999 email: info@newton.ac.uk www.newton.ac.uk



EPSRC
Pioneering research
and skills

 **Science & Technology
Facilities Council**

E · S · R · C
ECONOMIC
& SOCIAL
RESEARCH
COUNCIL

 **BBSRC**

 **NATURAL
ENVIRONMENT
RESEARCH COUNCIL**